

# Storage, installation, operation and maintenance instructions

(DOC-011)

## 1. General

- 1.1. All products are manufactured in conformance with EU statutory and regulatory requirements and are individually pressure and leak tested. It is our customer's responsibility to assure the conformity of the products with local requirements in the country of the installation.
- 1.2. Selection, installation, operation and maintenance of the product shall be carried out by qualified and authorized personnel, in accordance with statutory and regulatory requirements and best engineering practice. In particular, the personnel shall be aware of potential risks related to the product safety and environment.
- 1.3. The customer shall have knowledge and understanding of the General Business Conditions of LEEL Coils Europe s.r.o. (on order confirmations and invoices).
- 1.4. Operator of a system incorporating the product shall be respecting all relevant statutory and regulatory requirements, in particular as far as concern the work safety, leak detection and refrigerant handling.

## 2. Storage

- 2.1. The products are delivered in a package on a palette. Any damages of the package or any other visible traces of an incident shall be detected at the reception of products and recorded in the forwarder's transportation documentation.
- 2.2. The products tubes circuits are filled by dry air and the products shall be stored in a dry place, at the exemption of chemicals, oils, lubricants, dust and mud native from building activities, of direct sunlight, in order to prevent corrosion of tubes, casing and damage of the paint.

## 3. Installation

- 3.1. Before installation, the installer shall verify that all characteristics of the product and of the unit or system where the product is being incorporated are compatible.

- 3.2. The product incorporation in a system shall be compatible with the product design pressures and temperatures. Standard design pressures and temperatures are shown in DOC-008; for a specific product, allowed group of refrigerants and maximum allowable pressure PS are displayed on the product drawing that is validated by the customer.
- 3.3. The chemical composition of the air passing the coil shall be compatible with fin and tube material. Special materials as tinned copper, polymeric pre-coated fins, other suitable anticorrosive coatings etc. might be used for certain corrosive environments.
- 3.4. Foreign particles in the air will decrease the coil efficiency and may cause damage of the coil; put a sufficient protection grid and air filter when appropriate.
- 3.5. LEEL Coils Europe s.r.o. makes no warranty regarding copper or aluminum corrosion for the customer's specified types of these materials due to the operation environment. Even minor changes in the operation environment may have a negative impact - for example, small increases in temperature, changes in acidity, presence of trace elements such as **halides**, concentration, and velocity over the surface.
- 3.6. The refrigerant used shall be compatible with the tube material (copper, aluminum). In particular, the refrigerant must not contain components initiating intensive corrosion or stress corrosion cracking (SCC) of Al or Cu and its alloys (e.g. for Cu : NH<sub>4</sub><sup>+</sup>, Cl<sup>-</sup>, formic acid etc). The aluminium alloys mainly prone to SCC belong to the alloy series EN AW-2xxx, EN AW-5xxx (Mg > 3 wt%) and EN AW-7xxx..
- 3.7. The presence of foreign particles in the refrigerant may cause irreparable damage of the coil. Therefore an efficient and well-adapted filter shall be incorporated.
- 3.8. Coil shall be protected against any risk of damage due to excessive vibrations, even temporary, which could occur during unit operation or operation of other equipment close by (transmitted by floor, frame, pipes, valves etc.).

- 3.9. The coil is not structural element. The coil shall be fixed by its casing to a solid frame or platform. If the height of a vertical coil exceeds 1.5 m, back supports shall be used. For horizontal coils, coil deflection shall be eliminated. Return bends and headers mustn't be used to fix the coil in any case.
- 3.10. The coil is designed for either vertical or horizontal use, depending on the coil circuiting and position of connections. Our sales engineer may specially validate use of the coil in a different position than that originally defined.
- 3.11. For horizontal fluid coils (water, brine or a different liquid heaters or coolers) with connections on the same side, inclination of 5 mm per every meter of the coil length (in the direction down to the header) is recommended in order to allow a safe discharge.
- 3.12. For coils with a fan plate, the weight of the fan mounted shall correspond to the solidity of the fixation (inserts, sheet-metal-screw etc.) and to the thickness of the metal. Fan supports shall be used where appropriate. For threaded inserts, the correct way of assembly (with spacers) shall be used.
- 3.13. The piping shall be designed in conformance with industry standards. Use correct pipe diameter, thickness and layout. Coils shall be protected against excessive vibrations from the piping; use flexible connections where appropriate. Coils may be connected in parallel only under very special circumstances.
- 3.14. When connecting the coil to the circuit, it is forbidden to adapt the position or orientation of the connections of the coil by a mechanical force. Carefully manipulate with capillaries position - may break in brazing areas ! If the coil is being connected by brazing, the coil header tubes and brazed joints should be protected properly against flame and heat.

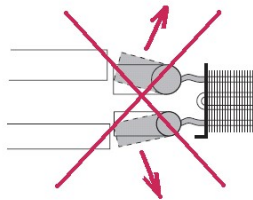

- 3.15. Fluid coils are normally designed to be connected to a closed loop circuit, eliminating oxidation. All air trapped in the circuit shall be

vented. For higher temperatures, oxygen shall be removed by a well-adapted separator. Refrigerant flow rate shall not exceed maximum admissible value. For water is min. speed 0,3m/s and max. 2,1 m/s. When the supply pipes remade of non-ferrous metal, take also all precautions necessary to avoid corrosion.

- 3.16. For fluid coils, freezing of the refrigerant typically causes irreparable damage of the coil. An effective protection device shall be installed. Precaution shall be taken during the installation and start-up.
- 3.17. For cooling coils, water condensate or ice can be formed on the fins. Droplets may follow the air stream. Design your system properly; use hydrophilic fin material, droplets eliminators and drying panes when appropriate. Ice formed and accumulated in the fin block may cause irreparable damage of the coil. Ice accumulation shall be eliminated by an effective and well-controlled defrosting device (or applying positive refrigerant temperatures if possible).
- 3.18. For volatile refrigerant coils (evaporator coils, condenser coils etc.) the installer shall ensure that all system parts are compatible with the refrigerant used and in accordance with all applicable statutory and regulatory requirements. One or several devices shall be installed to protect against any direct or indirect risks to persons or equipment in the case of the system design or installation fault. Right installation and filling tools and equipment shall be used during the installation and start up of the system.
- 3.19. Systems shall be sealed correctly and checked for leaks around all system elements and joints. Leak detection system shall be used wherever appropriate, in accordance with the applicable statutory and regulatory requirements.
- 3.20. Evaporator coils are designed to work properly between 50% and 100% of the design capacity. Multi-circuits shall be used whenever operation under 50% of the design capacity is needed. Refrigerant distributor of Venturi type shall be always in vertical position in order to assure equivalent refrigerant distribution and maximum capacity. The expansion valve should be mounted directly on the refrigerant distributor. If this is not possible, straight tube shall be used, as shortest as possible; any curved tube will worsen the refrigerant distribution which may

decrease the coil capacity to an important extent.

- 3.21. Do not use evaporator coil as a condenser (reversible) without prior consultation with your sales engineer.

#### 4. Operation

- 4.1. The system incorporating our product shall be operated strictly in the conditions defined by the system design and documentation including this instruction, by qualified and authorized personnel, in accordance with all statutory and regulatory requirements, including the applicable regulations on refrigerants.
- 4.2. The system and the coil shall be periodically inspected and maintained in accordance with the maintenance instructions of the manufacturer(s) and best practices.
- 4.3. For fluid coils, the quality of the fluid shall be periodically checked in order to prevent corrosion.

#### 5. Maintenance (recommended yearly period)

- 5.1. The system and the coil shall be periodically inspected and maintained in accordance with the maintenance instructions of the manufacturer(s) and best practices.
- 5.2. Before beginning any work on the system the personnel shall assure that all security precautions have been taken.
- 5.3. Check defrosting equipment (Including frost resistance of the medium). For fluid coils, protect the coils against freezing of the refrigerant. During a longer stoppage period, the temperature of the environment shall always be above the freezing point of the refrigerant.
- 5.4. Periodical cleaning of the coil shall be carried out, using pH neutral cleaning agents that do not attack the coil materials (biodegradable detergents). Dirty coil decreases the capacity of the system, its energy efficiency and may potentially cause system failures. Use flat shape of the water spray and keep the direction of the spray perpendicular to the fin edge. The cleaning period shall be adapted to the level of the pollution of the environment and shall in no case exceed 12 months.

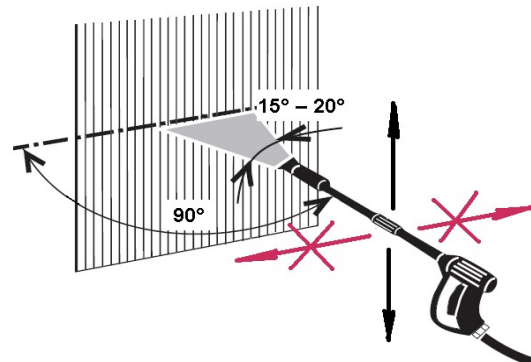

- 5.5. After cleaning, the coils shall be inspected visually for traces of corrosion. Eventually, all sources of corrosion shall be determined and eliminated, corrosion protection shall be applied (e.g. LCE Coating) or the coils shall be replaced. Nota: Tubes damage caused by reasons 2.2 3.3, 3.5, 3.6, 3.7, 3.15 are rarely visible.
- 5.6. Pressure test including venting inspection (to avoid leak of the refrigerant)
- 5.7. For fluid coils, the quality of the fluid shall be periodically checked in order to prevent corrosion.

#### 6. Problem solving

- 6.1. In case of any dysfunction, instructions relative to the system where the coil is incorporated shall be respected.
- 6.2. Guarantee conditions are specified in the General Business Conditions of LEEL Coils Europe s.r.o. (on order confirmations and invoices).
- 6.3. No intervention on the coil may be carried out before receiving a written confirmation of our representative.
- 6.4. Before contacting our responsible, please note the product traceability information – product part number, production lot, identification labels – together with the characteristics relative to the system and environment (operating temperatures, pressures, refrigerants, air flow rates, air temperatures etc.) and with a photograph of the defect if possible.